

MICROSTEER COLUMN INSTALLATION

65-66 MUSTANG



PART NUMBER:
FR40200M65



**IF YOU HAVE ANY QUESTIONS
CONTACT US AT:**

TECH-SUPPORT@FLAMINGRIVER.COM

OR CALL: (440) 826-4488

B E F O R E Y O U B E G I N

- Be sure the column you have selected is the proper length before you begin installation.
- DO NOT activate the column "tilt" mechanism before installation. This can cause injury, or damage to the column.
- You must install a neutral safety switch on all automatic transmissions. Your vehicle will start in any gear without it.
- The end of the Flaming River column is a 1"DD hollow shaft and Flaming River has a complete line of universal joints and shafts available to complete your steering installation after the column is installed in your vehicle.

BILL OF MATERIALS

ITEM	PART NO.	DESCRIPTION	QTY
1	FR40200	Microsteer Electric Power Assisted Steering Kit	1
2	FR20112AL	Column Dress Up Kit	1
3	FR20101M5	Mustang Aluminum Swivel Floor Mount	1
4	FR20114FD	Mustang Column Drop	1
5	FR20118	Female Connector Kit	1
6	103289	Mustang Microsteer Column Lower Extension	1
7	103282	Mustang Microsteer Column Upper Extension	1

MUSTANG COLUMN DIAGRAM:

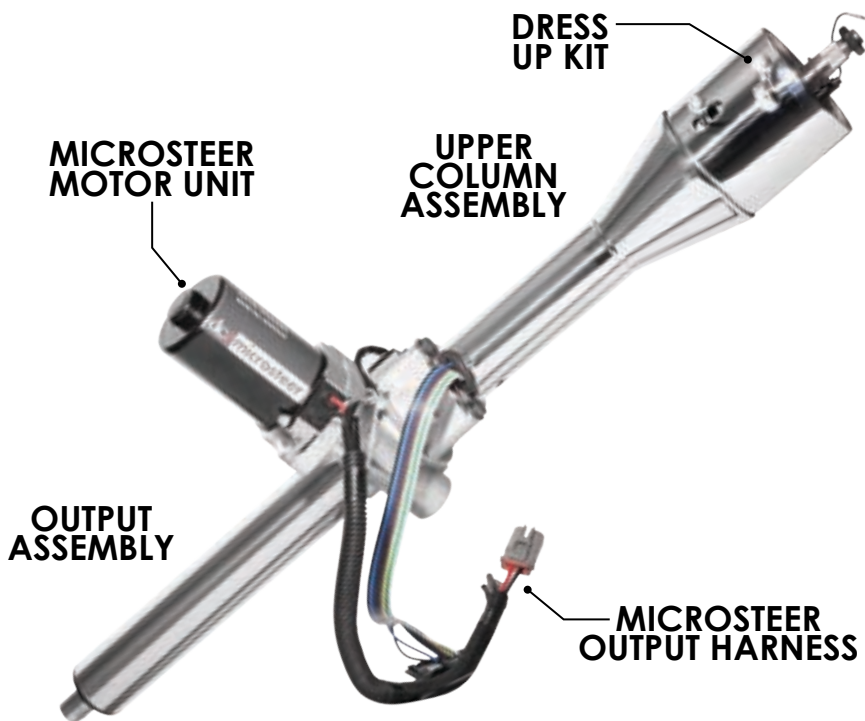

MUSTANG MICROSTEER COLUMN INSTALLATION

1. When installing the dress up kit, the turn signal arm using the phillips screw provided, then the tilt arm and finally the hazard knob using the screw provided. This process can be completed before or after installing the column in your Camaro's dash.
2. Position your vehicle's floor mount to the bottom of the steering column, do not fully tighten the mount until the column is in it's final position.
3. Install the column in the vehicle and install the dash mount or column drop in order to hold the column in place. Next re-adjust floor mount to fit snug to the floor and make any final adjustments before tightening all the clamps.
4. Connect the 4-1/4" black male plug from the column to your vehicle wiring harness receptacle.

PLEASE NOTE:

- There is a factory screw for the vent that may need to be shaved down just a small bit for the perfect fit, please be aware of this as it will prevent the electric steering motor from fitting nicely in place.
- Removal of the instrument cluster is not required for installation. We removed it to show proper placement of the Microsteer motor.



TIPS FOR A CLEAN INSTALLATION

1. Make sure each component is secured in a suitable fashion with the correct fasteners.
2. Tie all excess wiring together with a wire manager and make sure it does not hang down which can possibly interfere with the driver.
3. Make sure the Microsteer motor is positioned correctly
4. You might be required to relocate the vent control and parking brake control slightly toward the drivers side during installation.



NOW YOU SEE IT

NOW YOU DON'T



INSTALLING THE STEERING WHEEL

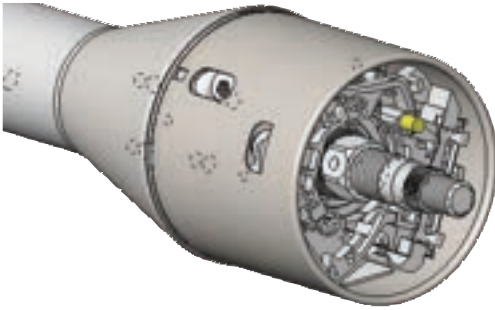

The spline on your new Flaming River steering column is a GM spline designed from 69 to present steering wheels without an airbag. The horn wire is furnished with your steering column and is pre-installed into the canceling cam.

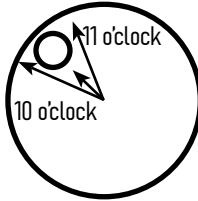
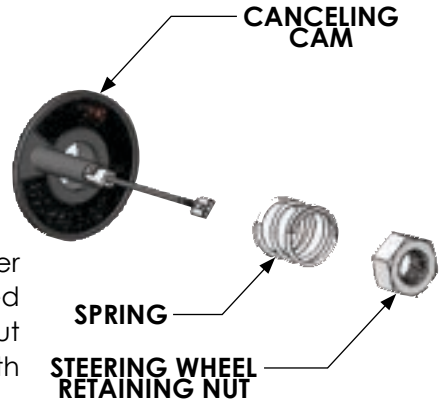

FIGURE 3



1. Position the canceling cam (as shown in figure 3) between 10 and 11 o'clock.



2. The compression spring is positioned over the column shaft on top of the canceling cam.



3. Place the steering wheel or adapter on the steering column shaft. Then place the retaining nut on the shaft and tighten, drawing down the wheel or adapter to the desired gap (we recommend approx. 1/16"). **DO NOT OVER-TORQUE**

MICROSTEER INSTALLATION INSTRUCTIONS

- MICROSTEER MOTOR
- ELECTRONIC CONTROL UNIT (ECU)
- TUNING BOX (POTENTIOMETER)
- WIRING HARNESS



HOW IT WORKS

The unique Microsteer tuning box allows you to adjust the amount of assistance by using a rotary potentiometer or, if you prefer, you can make the system speed sensitive by connecting a wheel speed signal to the tuning box. A mode selection switch on the box allows you to choose your preferred method, manual or wheel speed.

PLEASE REVIEW THE IMPORTANT INFORMATION ON THIS DOCUMENT BEFORE ATTEMPTING INSTALLATION

MECHANICAL INSTALLATION

Installation is easy - the MGU is designed to be fitted in line with the existing steering column by removing a section of column and inserting the MGU in its place.

The MGU can be mounted via the front or rear 3x M8 mounting holes. You need a suitable bracket to mount the MGU at a motor orientation that best suits your application.

MODE SELECTION SWITCH

The Microsteer tuning box has been specifically designed to allow you to swap between manual or wheel speed modes while on the move. Please note that switching from wheel speed to manual mode at high speeds could result in very light steering depending on the position of the potentiometer.

TAKE CARE WHILE SWITCHING MODES ON THE MOVE!

MICROSTEER INSTALLATION INSTRUCTIONS

The Microsteer system comes complete with a wiring harness (including protection fuse). The harness should be connected as follows:

1. Large black wire with ring crimp - battery negative
2. Large red wire with ring crimp - battery positive (12V DC only)
3. Small black wire - Battery Negative
4. Small red wire - Ignition +12V
5. Connect the two multiplugs from the wiring harness and the two multiplugs from the motor to the ECU. Each is a different style and will only fit in one position.
6. Plug the Microsteer harness into the tuning box via the 10-pin connector.

WHEEL SPEED INPUT

If you would like to make your system speed sensitive, a 3-pin wheel speed connector is provided on the Microsteer wiring harness. How you wire the connector depends upon whether you already have a wheel speed signal present or not. (The following steps can be disregarded if you only intend to use your Microsteer system in manual mode):

WHEEL SPEED SIGNAL ALREADY PRESENT

If your vehicle already has a digital wheel speed sensor fitted, locate the sensor signal wire. Splice this into (and then connect to) the Microsteer wheel speed connector on pin 2 (the yellow wire). The aim here is to share the signal between your vehicle's speedometer and the Microsteer tuning box.

NO WHEEL SPEED SIGNAL PRESENT

If you have no wheel speed sensor fitted on the vehicle, you will need our EPAS200W Microsteer speed sensor, which is not included in the FR40200M65 kit. The sensor is fitted to the wheel speed connector as follows, by pin number:

*(The unpinned male connector is included with the Microsteer Kit. Sensor sold separately **FR40200S**)*

1. +12V
2. SIGNAL
3. GROUND

The sensor should then be mounted on the vehicle to monitor either wheel or prop shaft rotation. The number of targets per revolution does not matter as the tuning box will automatically adjust for this.

OPERATION: MANUAL MODE

A small mode selection toggle switch is fitted to the tuning box. Middle position is wheel speed mode, the momentary position against the keyway to the top of the box is calibration mode and the latched position opposite the keyway is manual mode.

OPERATION: MANUAL MODE (CONTINUED)

Move the mode switch to the downward position. The system is now ready for testing. Ensure the vehicle is on the ground with the wheels fitted and the potentiometer turned fully counter-clockwise. Turn on the ignition. The red LED in the wiring harness near the ECU and the status LED on the tuning box should both flash once then switch off. Turn the steering wheel and you should have minimal power assistance.

Turning the potentiometer clockwise will increase the level of assistance available and the status LED on the tuning box will become brighter as assistance increases.

OPERATION: WHEEL SPEED MODE

Ensure a wheel speed signal or sensor is connected to the wheel speed connector and the ignition is off.

- Hold the mode switch in the calibration position (upward)
- Start the engine
- Release the calibration switch. The red status LED on the tuning box will now flash.
- At this point electric assistance is at its minimum setting.
- Drive the vehicle until you feel the weight of steering is comfortable. Briefly flick the mode switch back up to the calibration position and release. This sets the calibration speed.
- Above the calibration speed, assistance is minimal and the status LED is unlit.
- Below the calibration speed, assistance will gradually increase from minimum at the calibration speed to maximum when the vehicle is stationary - the status LED will get brighter as the level of assistance increases.

If you feel you need more assistance at a lower speed, simply repeat the above procedure and move the calibration point to a higher speed.

FAULT LED

A small red LED is fitted to the wiring harness near the ECU. In normal operations this will flash once on power up then switch off. In the unlikely event of a Microsteer fault this LED will flash a code. If this occurs, please consult support for assistance.

FLAMING RIVER WHEEL SPEED SENSOR - FR40200S

An optional wheel speed sensor is available for wheel speed mode. This can be installed on a wheel hub or drive shaft to determine vehicle speed for the Microsteer system to work more efficiently.

MICROSTEER TECHNICAL SPECIFICATIONS

OPERATING VOLTAGE	NOMINAL 13.8V DV
MAXIMUM CURRENT DRAW	30 AMPS
AVERAGE CURRENT DRAW	LESS THAN 2 AMPS
SYSTEM WEIGHT: MGU & ECU	4.4 KG / 9.7 LBS
MAXIMUM TORQUE OUTPUT	37 NM / 27 FT.LB
IP RATING	IP67
OPERATING TEMPERATURE	-20 TO 120° C / -4 TO 248° F
MOTOR RATED POWER	220 WATT
MGU SPLINE PATERN	11/16"- 36 BOTH ENDS

MICROSTEER DIMENSIONS

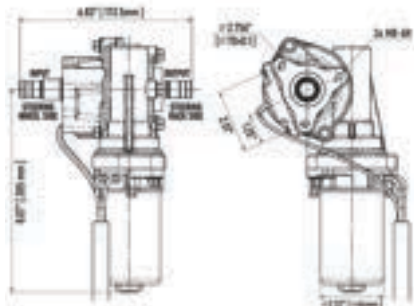

IMPORTANT INFORMATION

- THE STEERING SYSTEM OF A VEHICLE IS A SAFETY CRITICAL COMPONENT AND MODIFICATION OF THIS SYSTEM SHOULD ONLY BE CARRIED OUT BY A COMPETENT PERSON.
- THE MGU MUST BE MOUNTED IN THE CORRECT ORIENTATION OR IT WILL NOT FUNCTION. PLEASE SEE DIMENSIONS DRAWING FOR CLARIFICATION ON THE INPUT AND OUTPUT SPLINES.
- THE ELECTRIC MOTOR CAN BE MOUNTED SO IT POINTS UP, DOWN, LEFT OR RIGHT TO SUIT YOUR INSTALLATION NEEDS.
- ENSURE THE UNIT IS ADEQUATELY MOUNTED - A TORSIONAL FORCE IN EXCESS OF 60NM/45LB.FT. CAN EASILY BE GENERATED BY THE DRIVER AND STEERING SYSTEM COMBINED.
- DO NOT WELD UPON ANY PART OF THE MICROSTEER MOTOR OR ECU - ELECTRONICS ARE CONTAINED WITHIN THE UNITS THAT WILL BE DAMAGED BY THIS PROCESS.
- THE MICROSTEER SYSTEM IS NOT SUITABLE FOR VEHICLES THAT REQUIRE ANY CONTROLS TO PASS ALONG THE INSIDE OF THE STEERING COLUMN AS THE SHAFT IS SOLID.

ADDING A SPEED SENSOR FOR MICROSTEER WHEEL SPEED MODE

You may elect to add a wheel speed sensor to enable wheel speed mode with the Microsteer unit. This sensor can be purchased as an optional component and must be installed per these instructions.



FR40200S

MECHANICAL INSTALLATION

The speed sensor should be mounted so that the sensor face is positioned approximately 1-2mm (0.04" - 0.08") from the rotating target.

The target can be any ferrous metal (e.g... a bolt head) on the propeller (drive) shaft that will change speed with the vehicle. See installation examples below:



SENSOR MOUNTED ON PROPELLER SHAFT



SENSOR MOUNTED ON BRAKE DISC

ELECTRICAL INSTALLATION

When installing the Flaming River FR40200S Speed Sensor, you will have to take the 3 pin connector out of the FR40200 Microsteer Kit (provided in a separate bag with an empty male connector and three pins) and strip the wires on the speed sensor, then install them as pictured in the image below. The sensor should be connected to the Microsteer wiring harness (using the connector provided in the kit) and wired as follows:

On the Microsteer main wiring harness, the 3 pin connector has a green, yellow and red wire. These are pre-pinned from the main kit harness. When installing the connector on the new FR40200S speed sensor, you need to make sure it is wired in this way:

PIN NO.	HARNESS SIDE WIRE COLOR	REFERENCE	SENSOR SIDE WIRE COLOR
1	RED	12V	BROWN
2	BLUE	SIGNAL	BLACK
3	GREEN	GROUND	BLUE

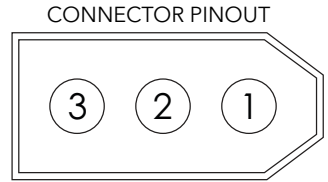

The numbers are printed on the cable entry side of the connector - 1 being at the "pointed" end. The speed sensor has a red LED built into the end of the sensor near the cable exit. When installation is complete, plug the sensor into the Microsteer harness and apply power. Rotate the target. Every time the target passes the sensor the LED should flash. If not, try moving the sensor closer to the target. Once the LED flashes, lock off the nuts on the sensor so they cannot move. The speed sensor installation is now complete.

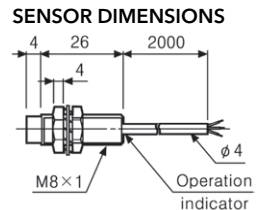
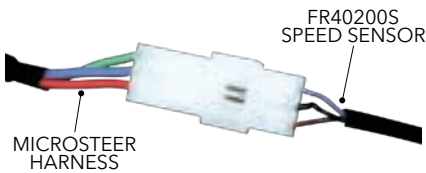

WARRANTY DISCLAIMER:

FLAMING RIVER'S LIMITED WARRANTY

Flaming River warrants its products to be free from defects in material and workmanship for a period of one (1) year after the date of purchase, except that: All electrical products other than the Big Switch are warranted for a period of ninety (90) days from the date of purchase. This Column and Microsteer Unit are warranted for a period of one (1) year. Flaming River's warranty liability is limited to the replacement of defective products. Flaming River is not liable for any labor costs associated with any warranty claim, or for any incidental or consequential damages. Improper installation, abuse, racing, and/or modification of the products voids this warranty. No warranty of merchantability or fitness for a particular purpose is made by Flaming River with respect to any of its products.

WARNINGS AND RECOMMENDATIONS

It is the customer's responsibility to determine the suitability of a given Flaming River product for the customer's uses. Likewise, it is the customer's responsibility to install a Flaming River product. Contact the vehicle manufacturer whenever installing a switch to confirm the appropriateness of using such a switch and the recommended placement of the switch on the vehicle. Use qualified chassis specialists for the installation of all steering related components. Be aware that the installation of certain Flaming River products may adversely impact a manufacturer's warranty with respect to certain vehicles and other manufactured goods. Flaming River will repair or replace any product found to be defective in material or workmanship. Improper installation, abuse, racing and/or modification VOID WARRANTY.

Flaming River is not responsible for any labor costs associated with any warranty.

Note: The information contained in this catalog is correct to the best of our knowledge and belief, having been compiled from reliable and official sources of information. However, Flaming River Industries, Inc. cannot assume responsibility for possible error.



FLAMING RIVER INDUSTRIES

800 POERTNER
BEREA, OH 44017
(800) 648-8022